



Access Covers & Frames

450x450mm Recessed FACTA Class B

Design Features

Single Recessed Block Pavior Infill cover and frame. Recessed lids a classified to enable either a block or slab infill.

- FACTA Class B (Pneumatic Wheel Load 5T)
- Recessed Manhole Covers for Block Paving & Slabbed Areas
- Usage: For external usage and areas with infrequent slow moving traffic up to 44 tonnes GLVW & Forklift Loading.
- Manufactured under an ISO 9001:2000 Quality System
- Finish: Hot dipped galvanised to BS EN ISO 1461 as standard
- Plain seated as standard
- Unsealed as standard

TECHNICAL FEATURES

Standard Opening Sizes	Block Size	Lid Recess	Frame Depth
450x450	up to 80mm	100mm	113mm

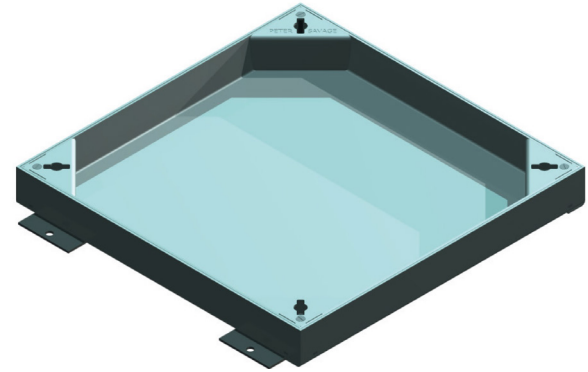

FEATURES

- Solid steel base plate
- Robust lifting eyes, pierced to accept standard profile keys
- Angled inner of lid to aid cover removal
- Specially produced from 4mm thick rolled steel section
- Single Sealed as standard
- Stainless Steel Edging Available

Option(s)

Edging in stainless steel Grade 304 or 316

Locking - Slotted Head/ Allen Head/ Hex Pin

Unsealed

Single or double Polyethylene Seal

Badged i.e. Water, Gas

M12 Threaded Lifting Points

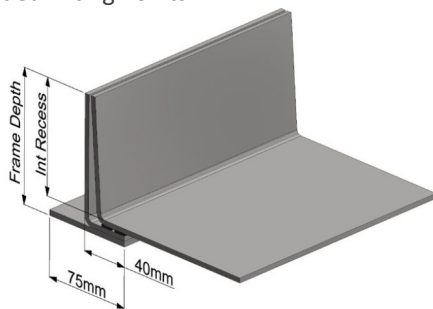

Recommended Rebate:
A = Depth Of Recess +30
B = 90

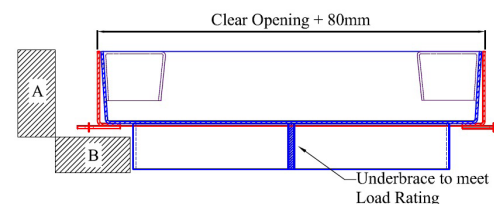
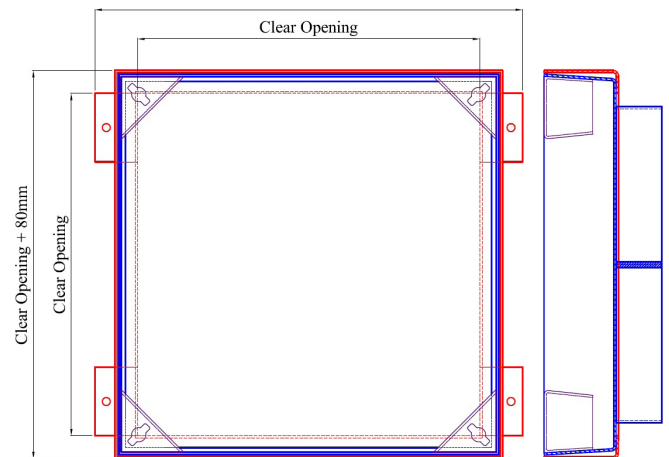
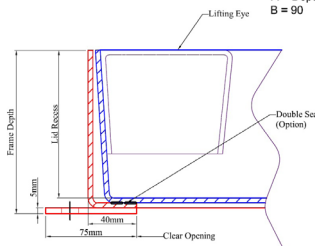

Schematic drawing, not to scale