

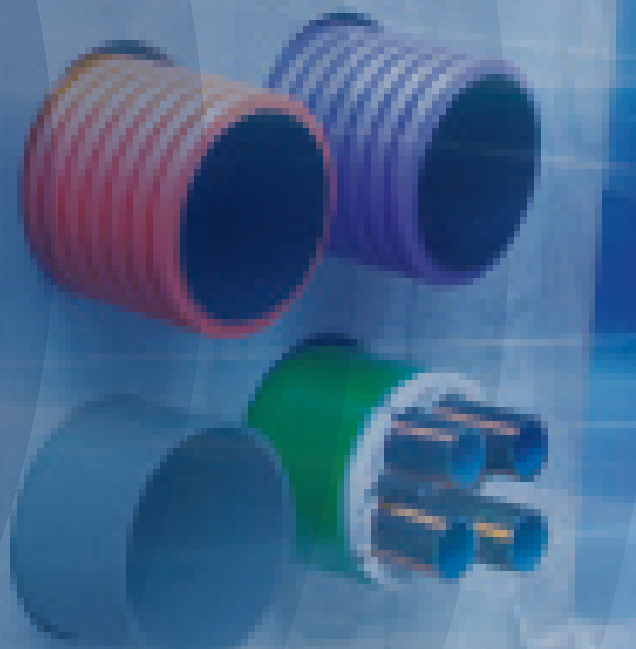

RADIUS
Systems

ACCESS CHAMBERS CABLE PROTECTION SYSTEM



Smarter Infrastructure

www.radiustelecoms.com



Quality

We are committed to the highest levels of quality for the design, manufacturing, performance, durability and delivery of our products. We source the best materials and we use modern and efficient manufacturing, inspection and testing methods and maintain an effective Quality Management System under the auspices of ISO 9001:2015.

We focus on high levels of customer service, courtesy, consistency and rapid response to suit our fast moving markets. Our culture is to be continually improving our service, products, systems and processes.



Environment

As a manufacturer, we take our environmental responsibilities very seriously and we work internally with customers and in partnership with suppliers to reduce carbon emissions across the whole supply chain.

In addition to the legislative compliance with ISO 18001 and ISO 14001 we have won several awards for our environmental initiatives.



Technical Support

We take pride in developing innovative yet cost effective solutions for telecom infrastructure requirements and developing long-term sustainable customer partnerships.

We strive to work closely with our partners in terms of technical support, training, product development and supply chain services to ensure that we provide the best tailored solutions.

Our expert team of engineers offer a design and development service for new products and the optimisation of existing products and we provide full technical field service backup for our products.



Health & Safety

The health and safety of our employees and customers is at all times of paramount importance to Radius Systems.

In addition to compliance with BS OHSAS 18001:2007 for the manufacture of polyethylene and PVC pipes and fittings for telecoms, gas, water and industrial applications, we also adhere to good working practices across our whole business, which is essential to achieve the high standards that we and our customers expect.



QUADBOX® ACCESS CHAMBER



Up to
40t



Approved

Quadbox® is a robust preformed underground access chamber system for use in all types of buried networks and utilities.

The Quadbox® system comprises of 150mm height stackable rings, which interlock to build variable depths. It is especially suitable for use in congested networks.

TECHNICAL FEATURES

- Fast Installation
- No heavy lifting equipment required
- Excellent performance service history
- Double wall construction using High Density Polyethylene (HDPE) based on structural foam technology
- Smooth outer wall with lip to key into backfill
- Stress free mouldings with excellent long-term performance
- Immediate load-bearing strength
- No need for concrete backfill
- Excellent chemical & weathering resistance
- Fully recyclable
- Free draining
- Inert material: no toxic dust from cutting
- Excellent vertical and side wall stiffness up to 40t

APPLICATIONS

Suitable for all types of direct buried networks and utilities

- Ideal for new build and retrofit overbuild
- Approved by British Telecom
- House building
- Telecom splice points & subscriber connection
- Cable drawing manhole

BENEFITS

- Simple stacking system, fast & reliable
- One stop fast installation
- Minimum disruption, reduced traffic management and install costs
- Robust & lightweight
- Excellent vertical & sidewall stiffness
- Generous overlap between sections for maximum integrity
- Suitable for use in congested networks
- Duct entry drill guides, highly adaptable
- Easy fit drop-in furniture



Dimensions - Clear Openings

| Code | Length (mm) | Width (mm) | Height (mm) | Weight (kg) | Top Load (t) | Pallet Qty Full Load | Pallet Qty Groupage |
|--------|-------------|------------|-------------|-------------|--------------|----------------------|---------------------|
| UY0000 | 300 | 300 | 150 | 2.4 | 12.5 | 52 | 52 |
| UY0001 | 600 | 450 | 150 | 5.9 | 12.5 | 20 | 20 |
| UY0002 | 725 | 255 | 150 | 6.5 | 25 | 45 | 37 |
| UY0003 | 915 | 445 | 150 | 14 | 40 | 30 | 26 |
| UY0004 | 1310 | 610 | 150 | 19 | 40 | 17 | 14 |

Available in 5 sizes:



300X300mm



600X450mm



725X255mm
BT 102

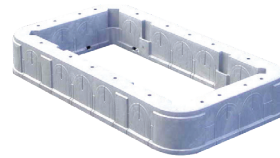

915X445mm
BT 104

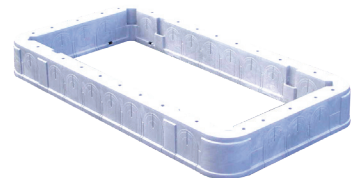

1310X610mm
BT 106

Up to
40t

TOP LOAD RATING

- Up to 40t depending on size, see table above

OPTIONS

- Pre-cut duct entries
- Pre-fitted floor
- Customisation for bespoke applications

Health & Safety

Product Weight

The chambers are lightweight with the heaviest section weighing less than 20kg. This complies with current European manual handling best practice guidelines and removes the need for lifting equipment.

Dust and Vibration

Duct entries are cut with a standard holesaw and the chamber material, being inert, presents no health risk to operatives or members of the public.

Chemicals

Preformed polyethylene chambers reduce exposure to concrete and other on-site chemicals.

RADBOX® ACCESS CHAMBER

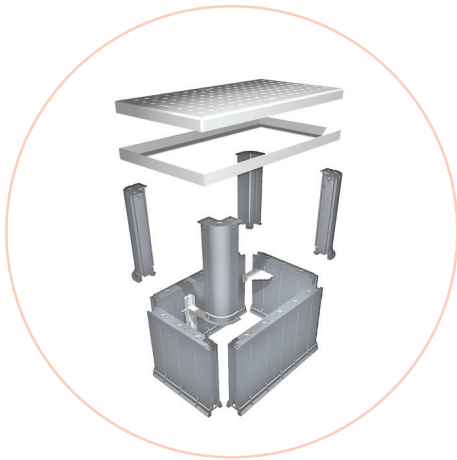

APPLICATIONS

Highly modular and adaptable system, suitable for use in Telecoms and Utilities enclosures alike

- Telecoms Joint Closures
- Utility Enclosures
 - Small and large water valves, cabinet bases
 - Hydrants
 - High voltage joints and turns
 - Power link boxes
 - Street Lighting / Traffic Signal
- Suitable for chambers, up to 2 x 2 x 2m
- Particularly suitable for special projects and bespoke applications

Radbox® is a high performance, preformed underground access chamber for all types of buried networks and utilities.

Radbox® is a modular system comprising of wall panels and corner pieces, which fit together to provide a wide range of chamber sizes.

The chamber is delivered as a compact lightweight flat-pack consisting of easily assembled components. It can also be supplied pre-built, if requested.

TECHNICAL FEATURES

- EN124 Class D400*
- Double wall construction using High Density Polyethylene (HDPE) based on structural foam moulding technology
- Stress free mouldings with excellent long-term performance and chemical resistance
- Free draining
- Immediate load-bearing strength
- Smooth outer wall with lip to lock into backfill
- Inert material no toxic dust from cutting
- No need for concrete backfill

*600x600mm chambers and above.

Suitable for pavements and slow traffic areas only.

BENEFITS

- One stop installation
- Simple - Fast - Reliable
- Lightweight, flat-packed for cost effective transportation & storage
- Maximum flexibility of duct entry location in side or end walls
- Excellent vertical & sidewall stiffness
- Excellent chemical & weathering resistance



System Components

The Radbox® system consists of interlocking panels, corners and joint pins which fit and stack together to create almost any size of chamber.

Interlocking panels and corners

- 5 basic single panel sizes: 450mm, 600mm, 750mm, 900mm, 1050mm
- A simple chamber is created using 4 panels and 4 corners
- For larger sizes, basic panels can be easily joined with a joint pin to create extended sides

Modular height

Components are available in a choice of 500mm and 150mm height

Sections of either height can be stacked in any combination to achieve the desired depth.

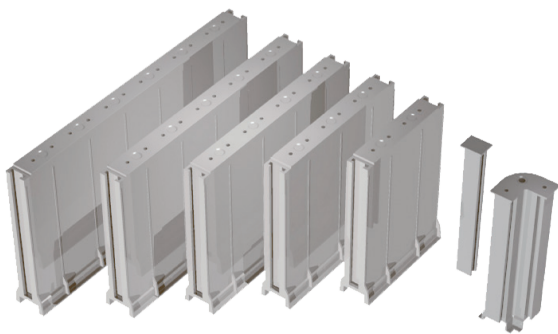

Options

- Pre-cut duct entries
- Pre-fitted furniture
- Pre-fitted floor
- Delivered flat packed or fully assembled

Dimensions - Clear Openings

| | | | | | | | | | | |
|----------------------|------|------|------|------|------|----------------------|------|----------------------|------|------|
| Single Panels (mm) | 450 | 600 | 750 | 900 | 1050 | | | | | |
| Extended Panels (mm) | 825 | 975 | 1125 | 1200 | 1275 | 1350 | 1425 | 1500 | 1575 | 1650 |
| | 1725 | 1800 | 1875 | 1950 | 2025 | | | | | |
| | | | | | | 2- Panel Combination | | 3- Panel Combination | | |



Flat Pack

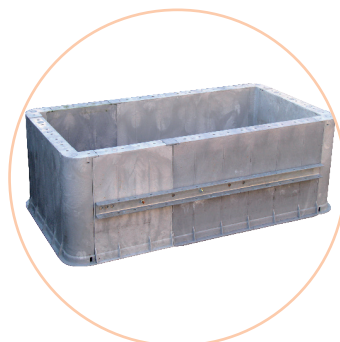

Extended panels



Cross Joint
Multichamber



RADIUS

Systems





Cable Management Accessories

QUADBOX® STEP



| Dimensions (mm) | Pack Qty | Product Code |
|-----------------|----------|--------------|
| 150 | 1 | UY0010 |

- Galvanised to EN1461

QUADBOX® CABLE BEARER KIT

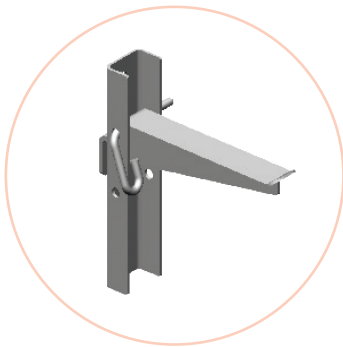

| Length (mm) | Pack Qty | Product Code |
|--------------|----------|--------------|
| 242 (bearer) | 2 | UY0011 |

- Incl. wall bracket (x 2), cable bearer (x 2) & locking pin (x 2)
- Galvanised to EN1461

QUADBOX® & RADBOX® CABLE BEARER



| Length (mm) | Pack Qty | Product Code |
|-------------|----------|--------------|
| 115 | 40 | UY0414 |
| 165 | 30 | UY0415 |
| 242 | 25 | UY0416 |
| 343 | 10 | UY0511 |
| 495 | 6 | UY0361???? |
| 648 | 6 | UY0362???? |

- Supplied with locking pin
- Galvanised to EN1461

RADBOX® WALL BRACKET



| Length (mm) | Hole Positions | Pack Qty | Product Code |
|-------------|----------------|----------|--------------|
| 178 | 1 | 25 | UY0417 |
| 278 | 2 | 10 | UY0425 |
| 508 | 5 | 10 | UY0418 |
| 813 | 9 | 8 | UY0419?? |
| 1270 | 15 | 6 | UY0426 |
| 1575 | 19 | 4 | UY0382??? |
| 1880 | 23 | 4 | UY0383??? |

- Bolt-on type
- Supplied with fixings
- Galvanised to EN1461



RADBOX® STEP

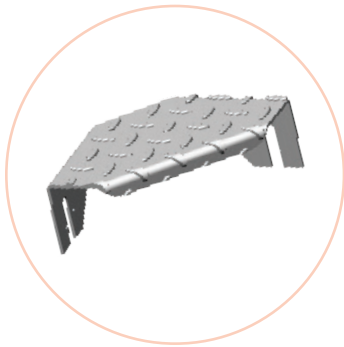

| Dimensions (mm) | Pack Qty | Product Code |
|-----------------|----------|--------------|
| 150 | 1 | UY0388 |

- Galvanised to EN1461
- Bolt-on type
- Anchor Irons No 4
- Cable Loop H?????
- Bell Booth Duct En??
- Hole Saws

PLASTIC FLOORS

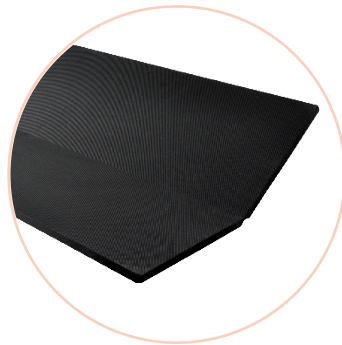

Standard style (can be supplied pre-fitted) or “Drop-in“ style

CABLE LOOP BOX



The Cable Loop Box can be easily mounted to a chamber wall:

- Simply use screws for preformed plastic chambers such as our Radbox & Quad-box
- Use screws and wall anchors for concrete or brick chambers.

The ducting can be inserted into the specified seals and the cable then installed around the central core of the Cable Loop Box.

[Contact us for a detailed datasheet](#)

BENEFITS

- Protects excess cable or duct from damage
- Capable of storing approx 50m of cable (based on 9mm OD)
- Rodent resistant design with sealed entries
- Total of four cable entries for various options of duct input and output
- Uses the same wide range of seals as Radius Matrix² tube closures
- Retrofittable, can be installed any time, any place
- Ergonomic design for ease of access
- Cable diameter limiting centre core to prevent microbending

Covers and Frames

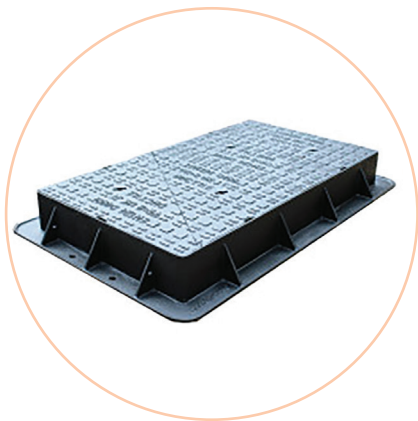

Ductile

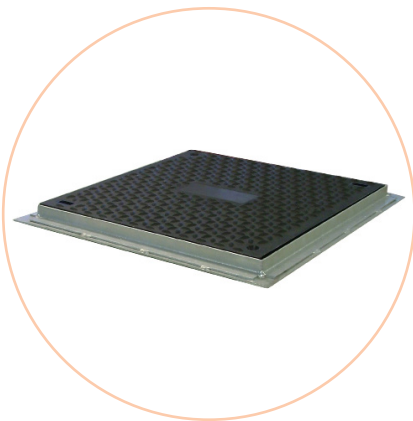

Composite

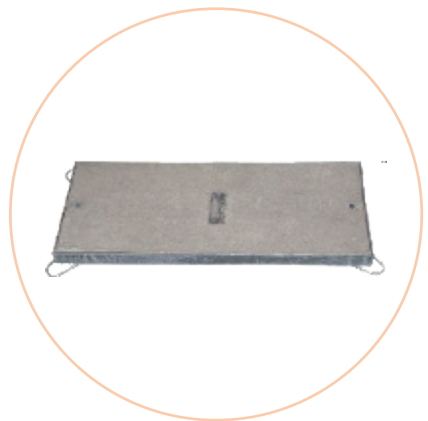

Concrete

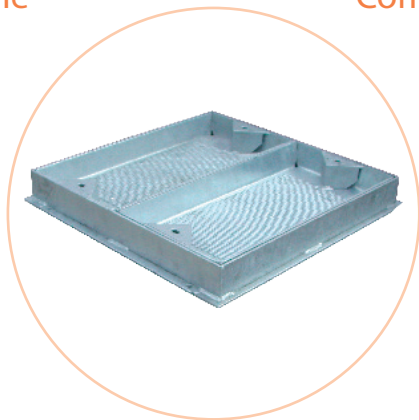

Recessed

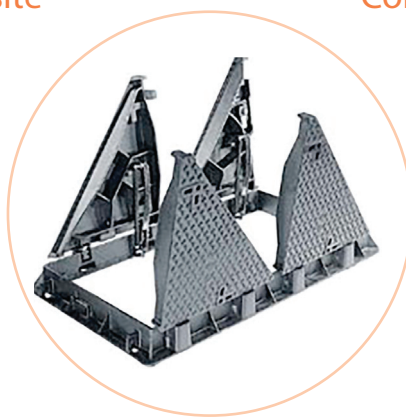

Ductile Hinged

Covers and Frames

Covers and frames can be provided to suit the installation location.

- B125 Ductile Iron Standard sizes available with ductile iron or galvanised steel frames.
- B125 Concrete Infill. Available for any size.
- C250 Ductile
- D400 Ductile. Suitable for aggressive locations.
- A15

Ranges

- Ductile iron
- Composite
- Concrete
- Recessed
- Ductile Hinged

Options

- Locking
- Rising frame
- Custom Badging
- Security plates



Custom Solutions

In addition to our standard range, boxes can be customised to suit your requirements.

An example is the RadBox® Minipillar chamber pictured below, developed and custom made to suit the requirements of utilities electricity supply.

The boxes are factory prepared to accommodate the customer's cabinet and have pre-cut duct entries ready for use.



Installed Chambers

See below typical chamber installations in greenfield conditions.

QuadBox®



RadBox®



1. DEFINITION

"the Company" shall mean Radius Plastics Limited;

"the Purchaser" shall mean the person(s), firm or company who purchases the Goods from the Company;

"Contract" shall mean any contract between the Company and the Purchaser for the sale and purchase of the Goods incorporating these Conditions;

"Contract Price" shall mean the total price for the Goods to be supplied under the Contract;

"Goods" shall mean any goods agreed in the Contract to be supplied to the Purchaser by the Company (including any part or parts of them).

2. APPLICATION OF TERMS

2.1 Subject to any variation under condition 2.3 the Contract will be on these Conditions to the exclusion of all other terms and conditions (including any terms or conditions which the Purchaser purports to apply under any purchase order, confirmation of order, specification or other document).

2.2 No terms or conditions endorsed upon, delivered with or contained in the Purchaser's purchase order, confirmation of order, specification or other document will form part of the Contract simply as a result of such document being referred to in the Contract.

2.3 These Conditions apply to all the Company's sales and any variation to these Conditions and any representations about the Goods shall have no effect unless expressly agreed in writing and signed by an authorised representative of the Company. Nothing in this Condition will exclude or limit the Company's liability for fraudulent misrepresentation.

2.4 Each order for Goods by the Purchaser from the Company shall be deemed to be an offer by the Purchaser to purchase Goods subject to these Conditions.

2.5 No order placed by the Purchaser shall be deemed to be accepted by the Company until a written acknowledgement of order is issued by the Company or (if earlier) the Company delivers the Goods to the Purchaser.

2.6 The Purchaser must ensure that the terms of its order and any applicable specification are complete and accurate.

Any quotation is given on the basis that no contract will come into existence until the Company despatches an acknowledgement of order to the Purchaser.

2.7 Any quotation is valid for a period of 30 days only from its date, provided that the Company has not previously withdrawn it.

3. DESCRIPTION OF GOODS

3.1 The description of the Goods shall be as set out in the Company's quotation.

3.2 All drawings, descriptive matter, specifications and advertising issued by the Company and any descriptions or illustrations contained in the Company's catalogues or brochures are issued or published for the sole purpose of giving an approximate idea of the Goods described in them. They will not form part of this Contract.

4. DELIVERY

4.1 Unless otherwise agreed in writing by the Company, delivery of the Goods shall take place at the Company's place of business.

4.2 The Purchaser will take delivery of the Goods within [14] days of the Company giving it notice that the Goods are ready for delivery.

4.3 Any dates specified by the Company for delivery of the Goods are intended to be an estimate and time for delivery shall not be made of the essence by notice. If no dates are specified, delivery will be within a reasonable time.

4.4 Subject to the other provisions of these Conditions the Company will not be liable for any direct, indirect or consequential loss (all three of which terms include, without limitation, loss of profits, loss of business, depletion of goodwill and like loss), costs, damages, charges or expenses caused directly or indirectly by any delay in the delivery of the Goods (even if caused by the Company's negligence), nor will any delay entitle the Purchaser to terminate or rescind the Contract unless such delay exceeds [180] days.

4.5 If for any reason the Purchaser will not accept delivery of any of the Goods when they are ready for delivery, or the Company is unable to deliver the Goods on time because the Purchaser has not provided appropriate instructions, documents, licences or authorisations:

4.5.1 risk in the Goods will pass to the Purchaser (including for loss or damage caused by the Company's negligence);

4.5.2 the Goods will be deemed to have been delivered; and

4.5.3 the Company may store the Goods until delivery whereupon the Purchaser will be liable for all related costs and expenses (including, without limitation, storage and insurance).

4.6 The Company shall be entitled to make deliveries by instalments. Each instalment shall be a separate agreement to which these Conditions will apply.

4.7 If the Company delivers to the Purchaser a quantity of Goods of up to [10]% more or less than the quantity accepted by the Company the Purchaser shall not be entitled to object to or reject the Goods or any of them by reason of the surplus or shortfall and shall pay for such goods at the pro rata Contract rate.

5. RISKS

5.1 The Goods are at the risk of the Purchaser from the time of delivery.

6. RESERVATION OF TITLE

6.1 Ownership of the Goods shall not pass to the Purchaser until the Company has received in full (in cash or cleared funds) all sums due to it in respect of:

6.1.1 the Goods; and

6.1.2 all other sums which are or which become due to the Company from the Purchaser on any account.

6.2 Until such time as property in the Goods passes from the Company the Purchaser shall upon request deliver up such of the Goods as have not ceased to be in existence or resold to the Company. If the Purchaser fails to do so the Company may enter upon any premises owned occupied or controlled by

the Purchaser where the Goods are situated and repossess the Goods.

6.3 Until ownership of the Goods has passed to the Purchaser, the Purchaser must:

6.3.1 hold the Goods on a fiduciary basis as the Company's bailee;

6.3.2 store the Goods (at no cost to the Company) separately from all other goods of the Buyer or any third party in such a way that they remain readily identifiable as the Company's property;

6.3.3 not destroy, deface or obscure any identifying mark or packaging on or relating to the Goods;

6.3.4 maintain the Goods in a satisfactory condition and keep them insured on the Company's behalf for their full price against all risks to the reasonable satisfaction of the Company.

On request the Purchaser shall produce the policy of insurance to the Company; and

6.3.5 hold the proceeds of the insurance referred to in condition 6.2.4 on trust for the Company and not mix them with any other money, nor pay the proceeds into an overdrawn bank account.

6.4 The Purchaser may resell the Goods before ownership has passed to it solely on the following conditions:

6.4.1 any sale shall be effected in the ordinary course of the Purchaser's business at full market value; and

6.4.2 any such sale shall be a sale of the Company's property on the Purchaser's own behalf and the Purchaser shall deal as principal when making such a sale.

7. EVENTS OF DEFAULT

7.1 The Purchaser's right to possession of the Goods pending payment therefore shall terminate immediately if:

7.1.1 the Purchaser has a bankruptcy order made against him or makes an arrangement or composition with his creditors, or otherwise takes the benefit of any statutory provision for the time being in force for the relief of insolvent debt or (being a body corporate) convenes a meeting of creditors (whether formal or informal), or enters into liquidation whether voluntary or compulsory) except a solvent voluntary liquidation for the purpose only of reconstruction or amalgamation, or has a receiver and/or manager, administrator or administrative receiver appointed of its undertaking or any part thereof, or documents are filed with the court for the appointment of an administrator of the Purchaser or notice of intention to appoint an administrator is given by the Purchaser or its directors or by a qualifying floating charge holder, or a resolution is passed or a petition presented to any court for the winding up of the Purchaser or for the granting of an administration order in respect of the Purchaser or any proceedings are commenced relating to the insolvency or possible insolvency of the Purchaser; or

7.1.2 the Purchaser suffers or allows any execution, whether legal or equitable, to be levied on his/its property or obtained against him/it, or fails to observe/performance of his/its obligations under these Conditions or any other contract between the Vendor and the Purchaser or is unable to pay its debts within article 103 of the Insolvency (NI) Order 1989 or the Purchaser ceases to trade; or

7.1.3 the Purchaser encumbers or in any way charges any of the Goods.

8. PRICE

8.1 Unless otherwise agreed by the Company in writing the price for the Goods shall be the price in effect on the date of delivery or deemed delivery.

8.2 The price for the Goods shall be exclusive of any value added tax and all costs or charges in relation to loading, unloading, carriage and insurance all of which amounts the Purchaser will pay in addition when it is due to pay for the Goods.

9. PAYMENT

9.1 Payment of the price for the Goods is due on the last working day of the month following delivery.

9.2 Time for payment shall be of the essence.

9.3 If the Purchaser fails to pay the Company any sum due pursuant to the Contract the Purchaser will be liable to pay interest to the Company on such sum from the due date for payment at the annual rate of 1.5% above the base lending rate from time to time of [the Ulster Bank], accruing on a daily basis until payment is made, whether before or after any judgment.

9.4 All payments payable to the Company under the Contract shall become due immediately upon termination of this Contract despite any other provision.

9.5 The Purchaser shall make all payments due under the Contract without any deduction whether by way of set-off, counterclaim, discount, abatement or otherwise unless the Purchaser has a valid court order requiring an amount equal to such deduction to be paid by the Company to the Purchaser.

10. QUALITY

10.1 The Company warrants that (subject to the other provisions of these Conditions) upon delivery the Goods will:

10.1.1 be of satisfactory quality within the meaning of the Sale and Supply of Goods Act 1994; and

10.1.2 be reasonably fit for any particular purpose for which the Goods are being bought

if the Purchaser had made known that purpose to the Company in writing and the Company has confirmed in writing that the Goods are fit for the purpose as described by the Purchaser.

10.2 The Company shall not be liable for a breach of any of the warranties in condition 10.1 unless:

10.2.1 the Purchaser gives written notice of the defect to the Company and (if the defect is as a result of damage in transit) to the carrier, within 7 days of the date of delivery; and

10.2 The Company shall not be liable for a breach of any of the warranties in condition 10.1 unless:

10.2.1 the Purchaser gives written notice of the defect to the Company and (if the defect is as a result of damage in transit) to the carrier, within 7 days of the date of delivery; and



10.2.2 the Company is given a reasonable opportunity after receiving the notice of examining such Goods and the Purchaser (if asked to do so by the Company) returns such Goods to the Company's place of business at the Company's cost for the examination to take place there.

10.3 The Company shall not be liable for a breach of any of the warranties in condition 10.1 if:

10.3.1 the Purchaser makes any further use of such Goods after giving such notice; or

10.3.2 the defect arises because the Purchaser failed to follow the Company's oral or written instructions as to the storage, installation, commissioning, use or maintenance of the Goods or (if there are none) good trade practice; or

10.3.3 The Purchaser alters or repairs such Goods without the written consent of the Company.

10.4 Subject to conditions 10.2 and 10.3, if any of the Goods do not conform with any of the warranties in condition 10.1 the Company shall at its option repair or replace such Goods (or the defective part) or refund the price of such Goods at the pro rata Contract rate provided that, if the Company so requests, the Purchaser shall, at the Company's expense, return the Goods or the part of the such Goods which is defective to the Company

10.5 If the Company complies with condition 10.4 it shall have no further liability for a breach of any of the warranties in condition 10.1 in respect of such Goods

11. CLAIMS

11.1 All claims in respect of faulty goods must be submitted by the Purchaser in writing to the Company within seven days of delivery of the Goods.

11.2 All claims in respect of shortages in delivery must be notified by the Purchaser to the Company in writing within three days of delivery.

11.3 All claims in respect of non-delivery must be made in writing by the Purchaser to the Company within ten days of receipt by the Purchaser of an invoice or advice note (whichever is the earlier) in respect of those Goods.

12. ASSIGNMENT

12.1 The Purchaser shall not be entitled to assign this Contract or any part of it without the prior written consent of the Vendor.

12.2 The Company may assign this contract or any part of it to any person, firm or company.

13. LIMITATION OF LIABILITY

13.1 The following provisions set out the entire financial liability of the Company (including any liability for the acts or omissions of its employees, agents and sub-contractors) to the Purchaser in respect of:

13.1.1 any breach of these Conditions; and

13.1.2 any representation, statement or tortious act or omission including negligence arising under or in connection with this Contract.

13.2 All warranties, conditions and other terms implied by statute or common law (save for the conditions implied by section 12 of the Sale of Goods Act 1979) are, to the fullest extent permitted by law, excluded from this Contract.

13.3 Nothing in these Conditions excludes or limits the liability of the Company for death or personal injury caused by the Company's negligence or fraudulent misrepresentation.

13.4 Subject to conditions 14.2 and 14.3:

13.4.1 The Company's total liability in contract, tort (including negligence or breach of statutory duty), misrepresentation, restitution or otherwise, arising in connection with the performance or contemplated performance of this Contract shall be limited to the Contract Price; and

13.4.2 The Company shall not be liable to the Purchaser for any pure economic loss, loss of business, depletion of goodwill or otherwise, in each case whether direct, indirect or consequential, or any claims for consequential compensation whatsoever (howsoever caused) which arise out of or in connection with this Contract.

14. FORCE MAJEURE

14.1 The Company reserves the right to defer the date of delivery or to cancel the Contract or reduce the volume of the Goods ordered by the Purchaser (without liability to the Purchaser) if it is prevented from or delayed in the carrying on of its business due to circumstances beyond the reasonable control of the Company including, without limitation, acts of God, governmental actions, war or national emergency, acts of terrorism, protests, riot, civil commotion, fire, explosion, flood, epidemic, lock-outs, strikes or other labour disputes (whether or not relating to either party's workforce), or restraints or delays affecting carriers or inability or delay in obtaining supplies of adequate or suitable materials. Provided that, if the event in question continues for a continuous period in excess of 60 days, the Purchaser shall be entitled to give notice in writing to the Company to terminate the Contract.

15. GENERAL

15.1 Each right of remedy of the Company under the Contract is without prejudice to any other right or remedy of the Company whether under the Contract or not.

15.2 If any provision of the Contract is found by any court, tribunal or administrative body of competent jurisdiction to be wholly or partly illegal, invalid, void, voidable, unenforceable or unreasonable it shall to the extent of such illegality, invalidity, voidness, voidability, unenforceability or unreasonableness be deemed severable and the remaining provisions of the Contract and the remainder of such provision shall continue in full force and effect.

15.3 Failure or delay by the Company in enforcing or partially enforcing any provision of the Contract will not be construed as a waiver of any of its rights under the Contract.

15.4 Any waiver by the Company of any breach of, or any default under, any provision of the Contract by the Purchaser will not be deemed a waiver of any subsequent breach or default and will in no way affect the other terms of the Contract.

15.5 The parties to this Contract do not intend that any term of this Contract will be enforceable by virtue of the Contracts (Rights of Third Parties) Act 1999 by any person that is not a party to it.

16. JURISDICTION

16.1 The formation, existence, construction, performance, validity and all aspects of the Contract shall be governed by Northern Irish law and the parties submit to the exclusive jurisdiction of the Northern Ireland courts.

Have you got the complete set?

Download from www.radiustelecoms.com



Contact us to find out more:

Cable, Telecoms & Specials (CTS) Division

t: +44 (0)28 3844 6060

e: info@radiustelecoms.com

w: www.radiustelecoms.com



RADIUS
Systems

Contact us to find out more:

Cable, Telecoms & Specials (CTS) Division

t: +44 (0)28 3844 6060

e: info@radiustelecoms.com

w: www.radiustelecoms.com